

Spring Creek Mine Trail Cable Handling CPI

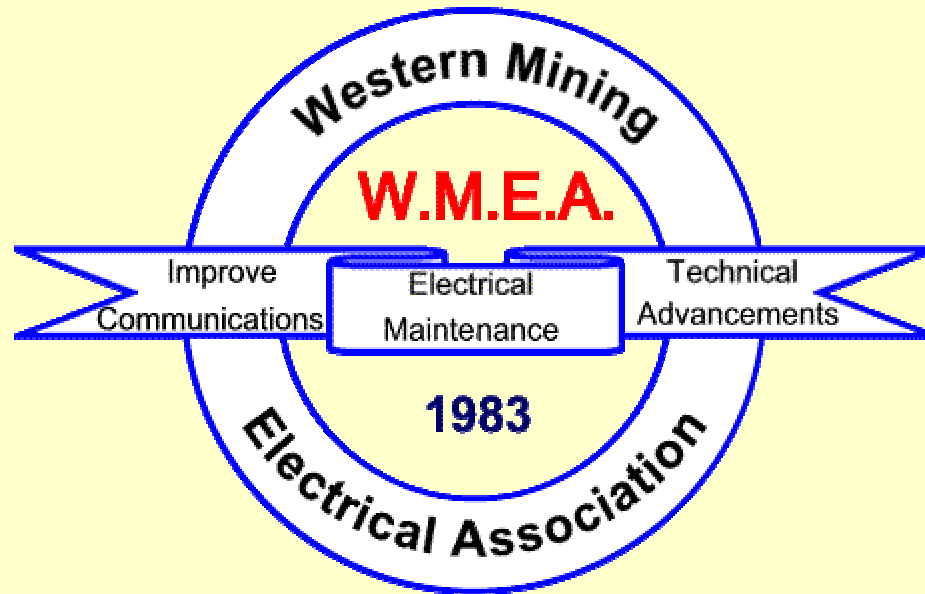

Rapid City, South Dakota

May 12 - 14, 2004

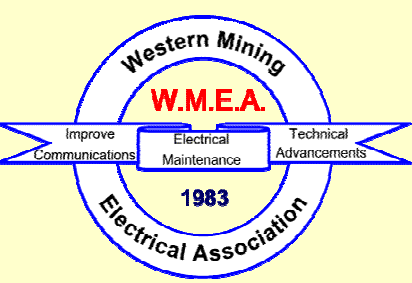

Presenters



- **Jon Vendela / Electrical Planner**
 - **CPI Project Introduction**
- **Joel Hendrickson / Electrical Lead**
 - **Soft-Start Installation**
- **Rick Scherer / Electrical Engineer**
 - **Soft-Start Design & Commissioning**

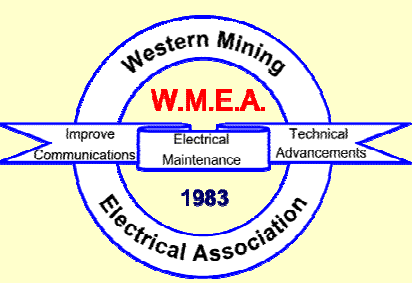

Continuous Process Improvement (CPI)



- **Jon Vendela CPI Trail Cable Handling Team Leader**
- **CPI Team to Identify Challenges and Goals**
- **Form team from different disciplines**
- **Visit and review other operations inside and outside Kennecott Energy**
- **Gather all ideas and focus on others success**
- **Evaluate ideas as related to SCC operations**
- **Present recommendations to management**

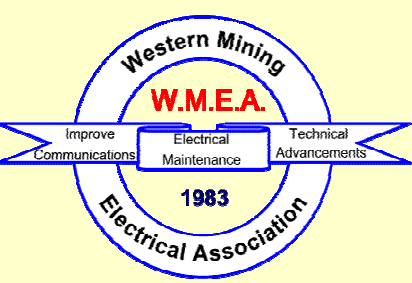

Summary

Challenges and Goals



- **Reduce cable handling injuries to mine personnel**
- **Improve Cable Handling Productivity**
- **Complete a lifting Time and Frequency study on 31 tasks**
- **Reduce risk factor**

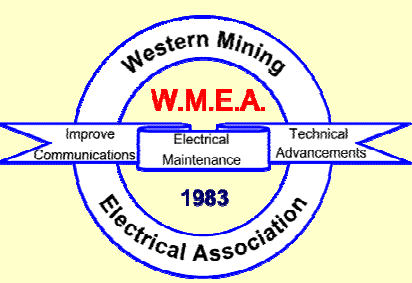

CPI Results Summary



- **17 Improvement Ideas were analyzed**
- **Cable weight reduction reduces risk of injury**
- **Reduce cable handling with improved planning**
- **Dragline capable of operating on smaller cable.....can we “Soft-Start” MG sets?**
- **Implementing this project will reduce risk factor by estimated 54%**

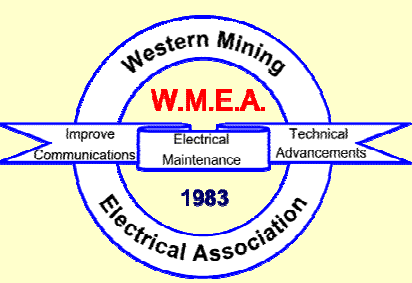

CPI Recommendations



- **Improve cable handling planning**
- **Install a soft start on the dragline**
- **Reduce trail cable size from 500MCM to 4/0, weight reduction, 12 to 6 lbs per foot**
- **Replace PLM connectors with J-Boxes, reducing personnel lifting exposure, 112 to 30 lbs**
- **Upgrade cable reel handler**

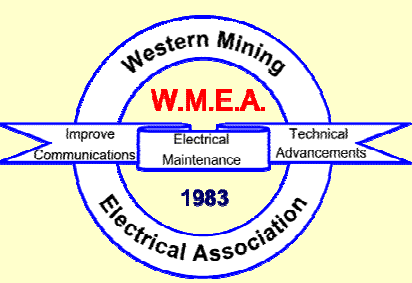

Project Approved



- **Kennecott Energy supported this project because of its health and safety benefits**
- **ESC of Fort Collins was consulted to size smaller cable**
- **Rick Scherer lead the design and commission**
- **Joel Hendrickson lead the installation with support from the Electrical Dept**

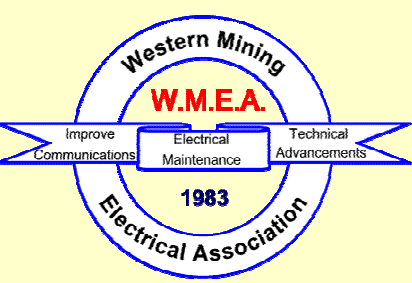

Cost of Project



- **Evaluated a 3500 HP VFD, installed costs exceed \$ 300K!**
- **Actual Costs:**
 - **Engineering and design studies** \$ 5K
 - **Soft Start hardware** \$20K
 - **Static Reeveing Hardware** \$ 5K
 - **Installation and Commissioning** \$25K**by Kennecott Energy**

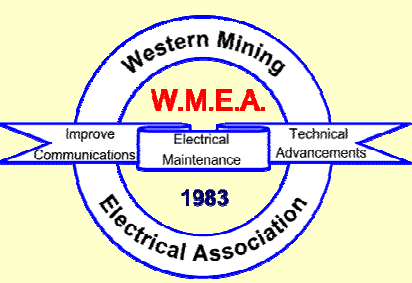

What is a Soft-Start?



- **Accelerating MG set, zero speed to a 100% synchronous speed, at a controlled rate**
- **First introduced to the mining industry in Australia due to “soft” power systems**
- **Technology, existing hardware and ingenuity allowed us to design / install / commission a functional DC soft-start**

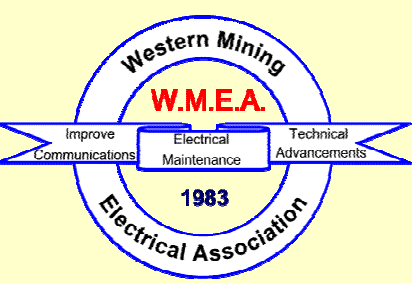

Benefits of Soft-Start System



- **Trail Cable weight reduction**
- **Reduces stresses on all associated electrical and mechanical motor starting components**
- **Variable speed provides for ease of field maintenance of commutators and slip rings**
- **SCC operations will no longer halt pit and plant operations when starting MG sets**
- **Future cable cost is greatly reduced**
- **Static reeveing allows maintenance personnel to reeve the hoist and drag drums, without MG sets**

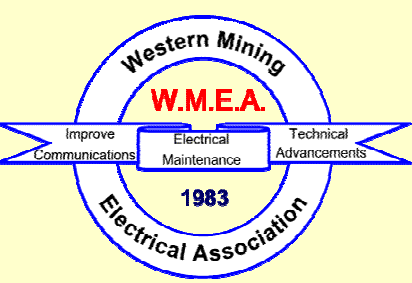

Design Concept



- **Power the hoist generators (as motors) to 101% of synchronous speed**
- **Required field weakening above static drive base speed**
- **Remove all power allowing the MG set to coast back to synchronous speed**
- **Close the vacuum contactors applying line voltage to synchronous motors with minimal line disturbance**

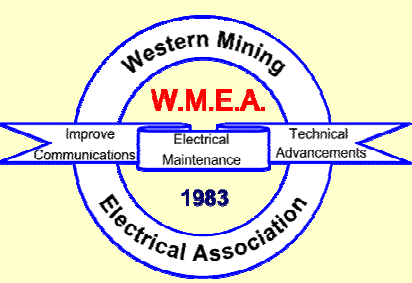

Design Plan



- **Use (SMFEX) as armature supply to hoist generators to base speed**
- **Use (HGFEX) as field supply to hoist generators via reversing contactors to allow field weakening above base speed**
- **Utilize PLC to control entire start process and return to normal run state**

Block Diagram

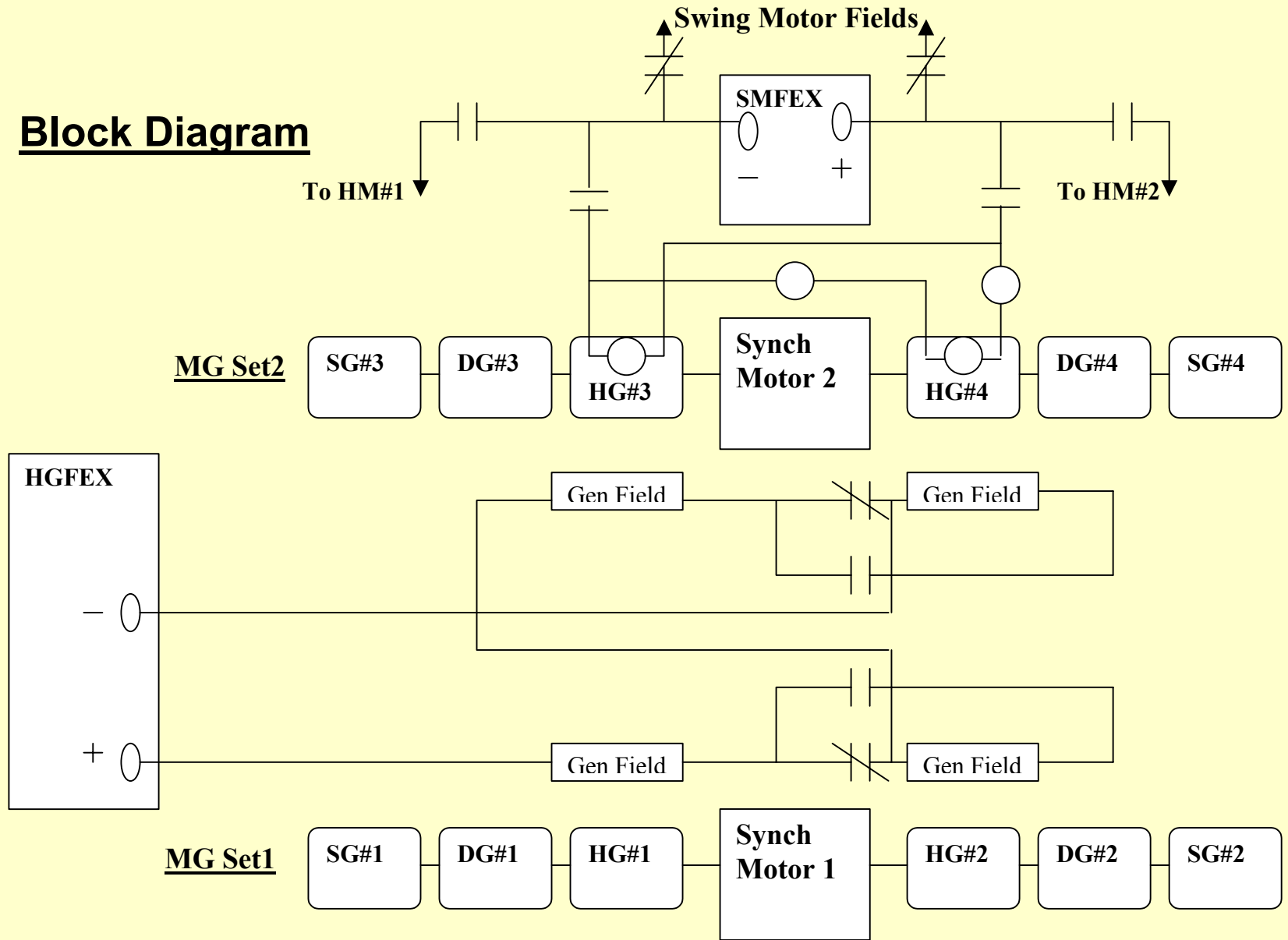

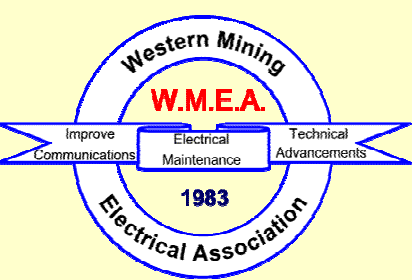

Soft-Start Armature Drive and Contactors



SMFEX Serves as PLC Controlled Voltage Regulated Energy Source to Base Speed

Contactors Serve as Isolation and Route Energy to Appropriate Hoist Generator as Prime Soft-Start Mover

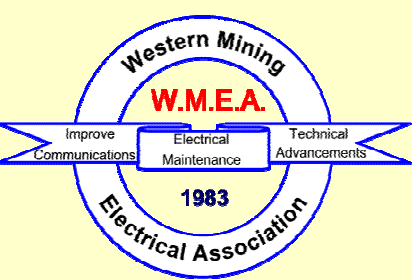

Phase Balance Relays

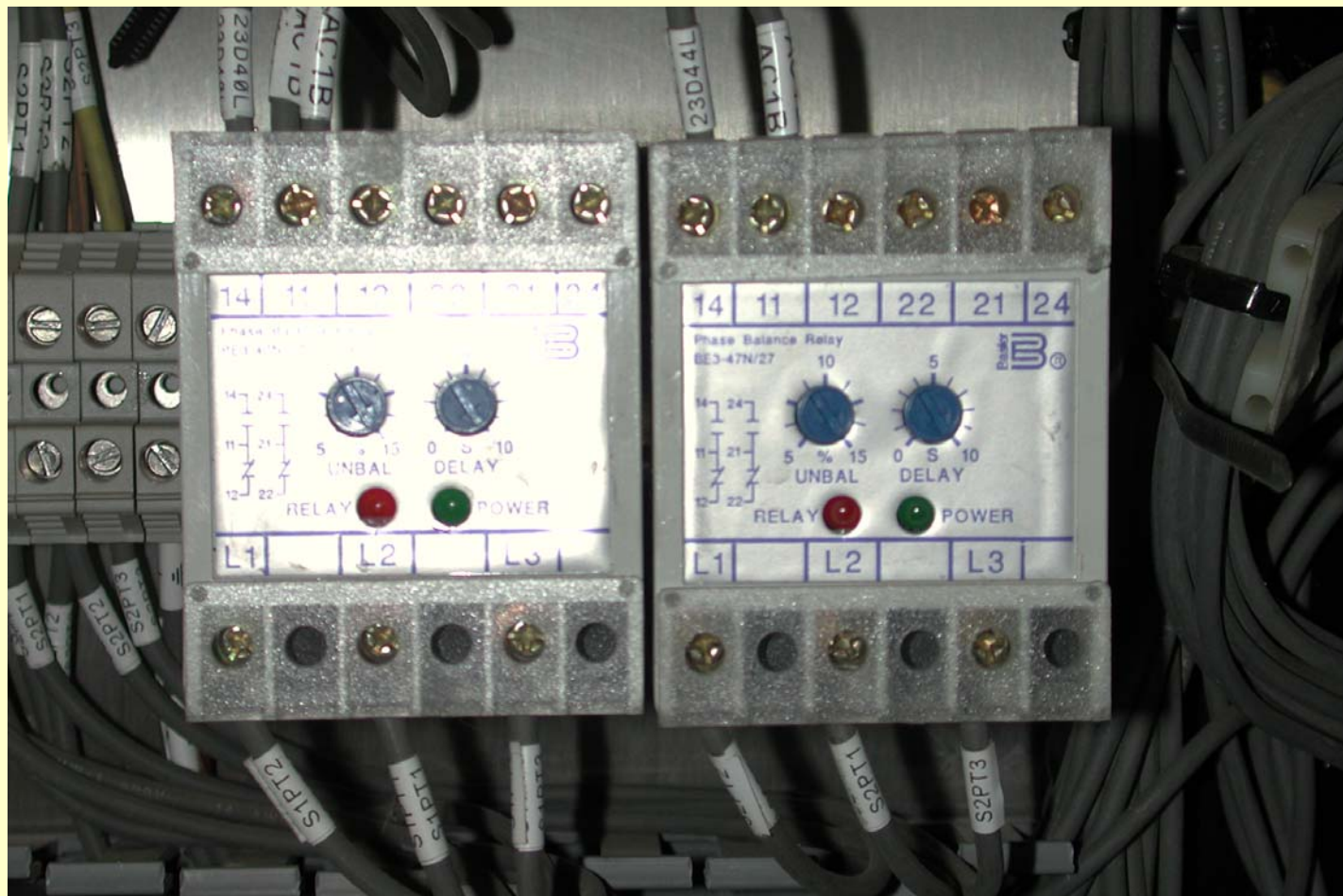

Phase Balance Relay Protection. Examines Rotation, Phase Loss & Unbalance Prior to Synchronization

Frequency Transducers



Frequency Transducers
 Monitor Synchronous Rotor
 Induced Voltage and
 Subsequent Frequency

Rotor Speed \propto Frequency

6 Pole Synchronous Machine

0 Hz =	0 RPM
15 Hz =	300 RPM
30 Hz =	600 RPM
45 Hz =	900 RPM
60 Hz =	1200 RPM

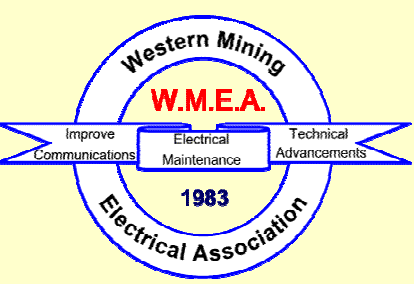

Hoist Generator Field Current Reversing Contactors



Normal Dig:

HG1 If →

HG2 If →

HG3 If →

HG4 If →

Soft-Start:

HG1 If →

HG2 If ←

HG3 If →

HG4 If ←

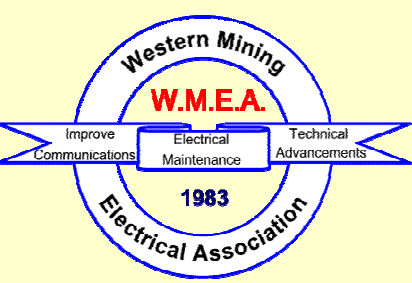

Installation Of Design



- **Hardware and wiring installed during PM's**
- **Hoist generator field wiring was most difficult as system had to be returned to run state each day**
- **HGFEX digital drive required additional programming, technical assistance provided by DCS**
- **PLC logic was created and installed to test MG set 1 only**

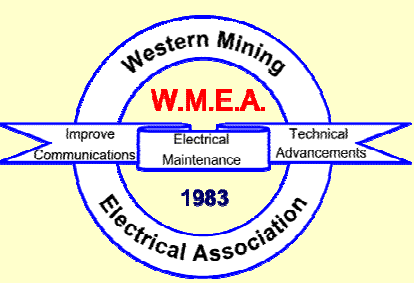

Commissioning The System



- **Challenge # 1:**

- **Hoist generator fields reconfigured for reverse rotation**
- **Eliminate field current on MG set 1 while MG set 2 is accelerated**

Block Diagram

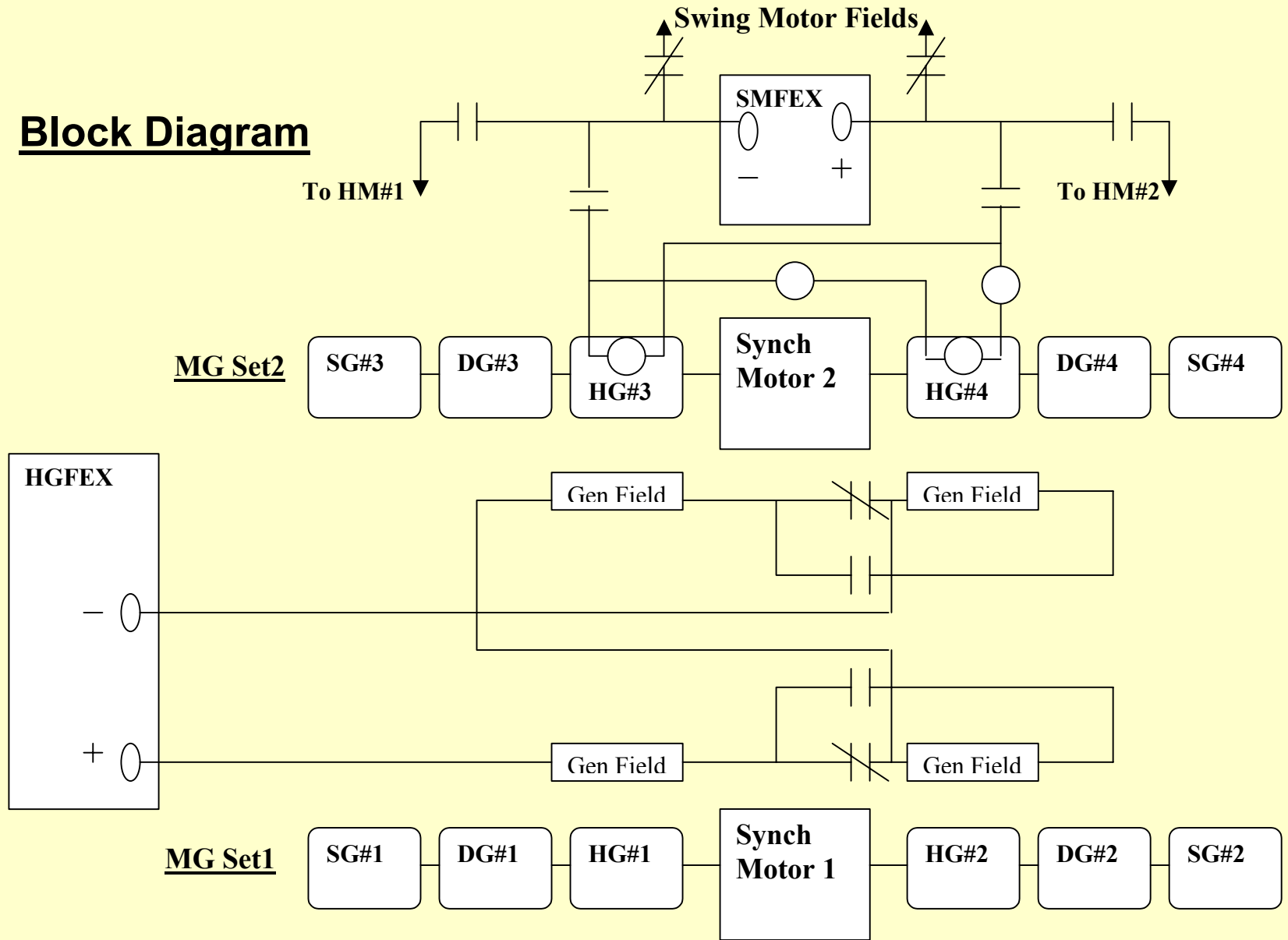

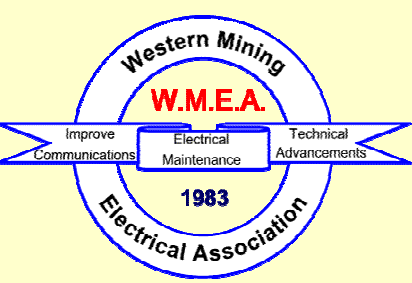

Commissioning



- **Challenge # 2:**
 - **HGFEX as applied to the hoist motion is programmed as an integrator, type 0 regulator**
 - **Reprogram HGFEX as current follower, thank you DCS for technical support**
 - **HGFEX was manipulated to a proportional regulator for soft start, returned to an integrated drive for dig mode**

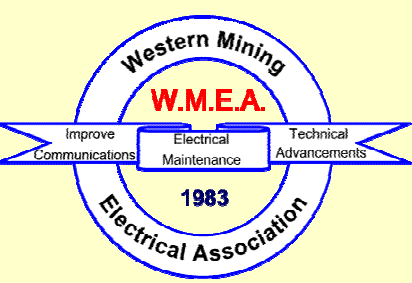

Commissioning



- **Challenge # 3:**

- **Adjust SMFEX to deliver sufficient breakaway torque**

- » $(T \propto \text{Armature Amps})$

- **SMFEX drive reconfigured from current controller to voltage controller**

- » $(\eta \propto \text{CEMF})$

- **Increase SMFEX current limit via external current limit to develop sufficient break-away torque**

- » “stick friction”

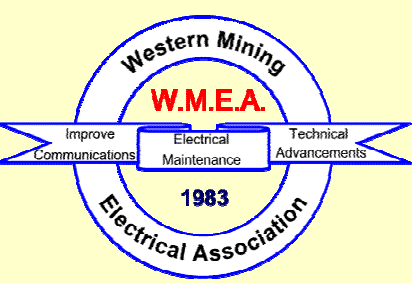

Other Challenges



- **Develop emergency stop and normal stop logic**
- **Consider and develop control logic for all possible faults and malfunctions**
- **Sequencing ramp up acceleration and field weakening logic**
- **How do we measure speed of MG set?**
- **Converting from soft-start acceleration mode to applying line voltage to the synchronous motors**
- **Accelerating MG 2 after MG 1 is “online”**
- **Finally, returning the drives and logic to a “normal” condition after both sets were “online”**

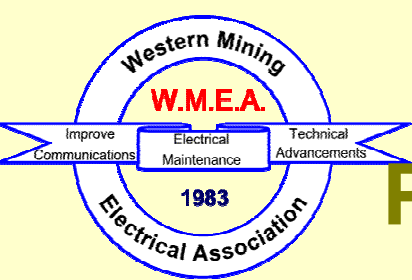

ATL Power System Data

Peak Mega-Watts Starting MG 1

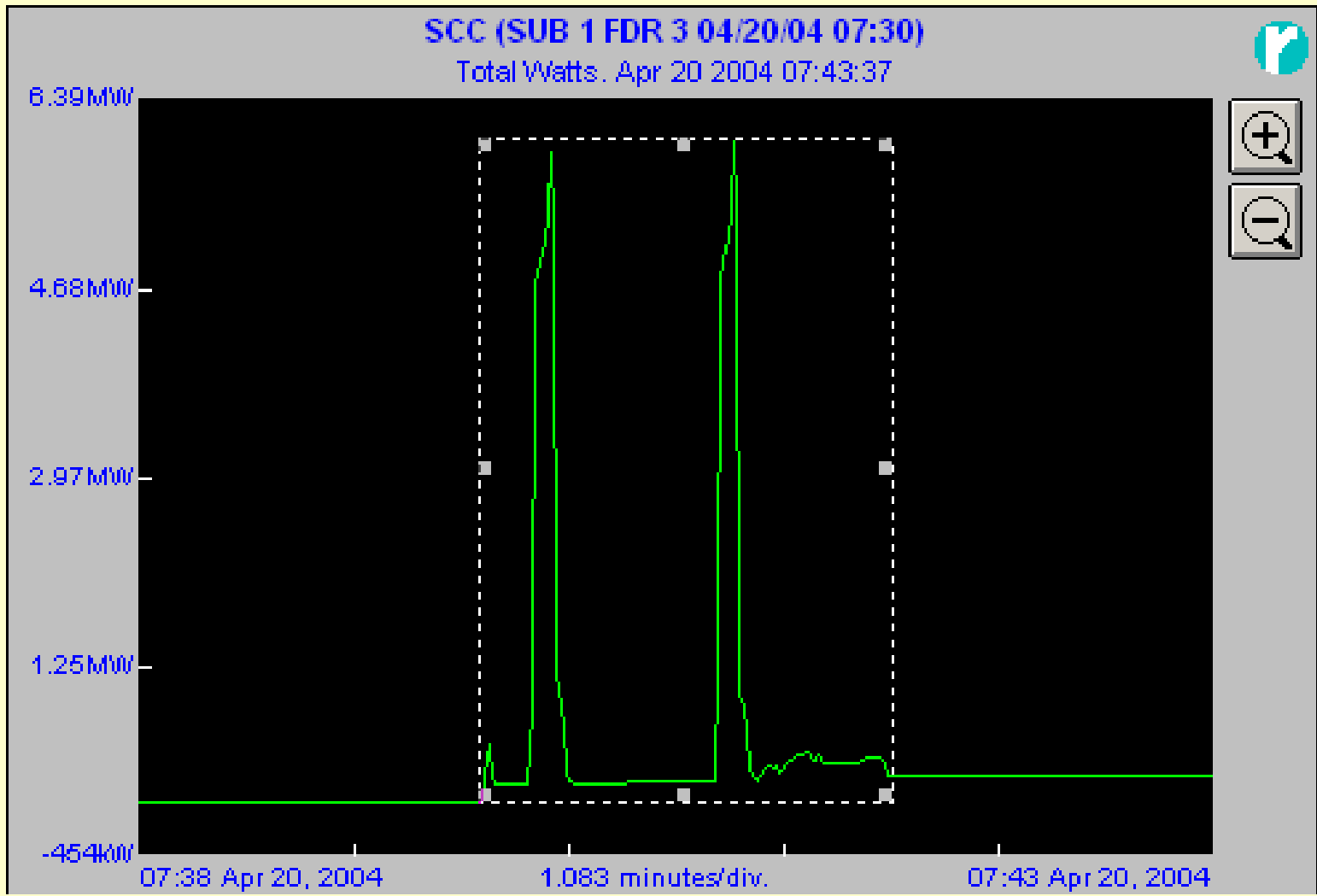

From:
4/20/2004
7:39:51

To:
4/20/2004
7:41:59

Span:
2:08

Peak:
6.04 MW

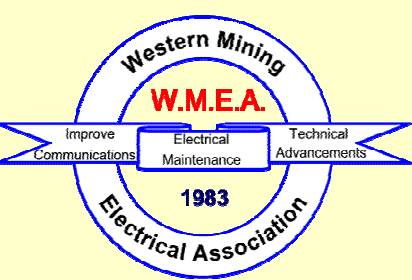

Soft-Start Power System Data

Peak KW During Soft-Start

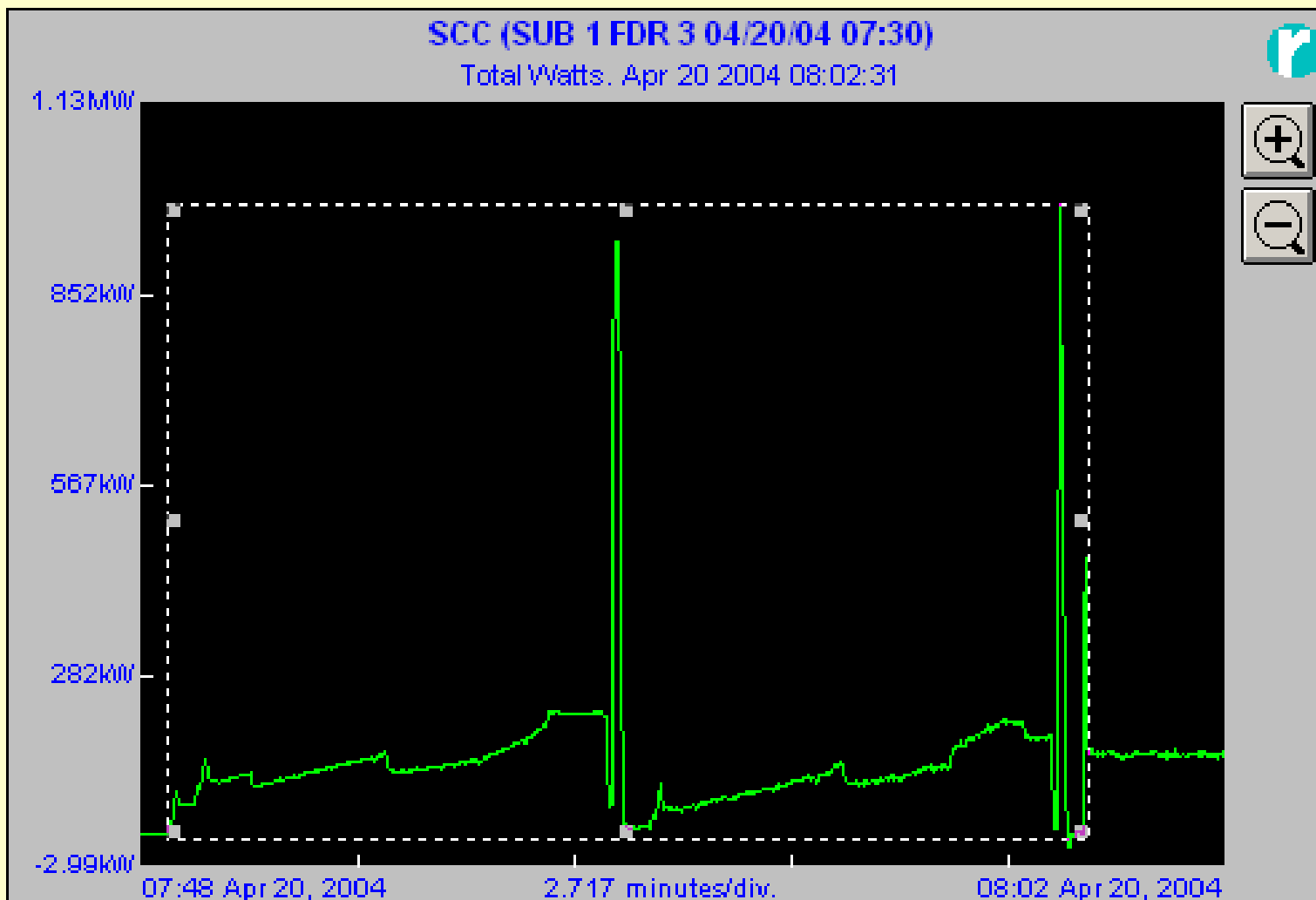

From:
4/20/2004
7:49:16

To:
4/20/2004
8:00:50

Span:
11:34

Peak:
953 Kw

Acceleration:
< 300 Kw

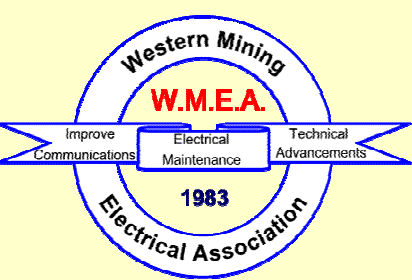

ATL Power System Data Peak MVA Starting MG 1

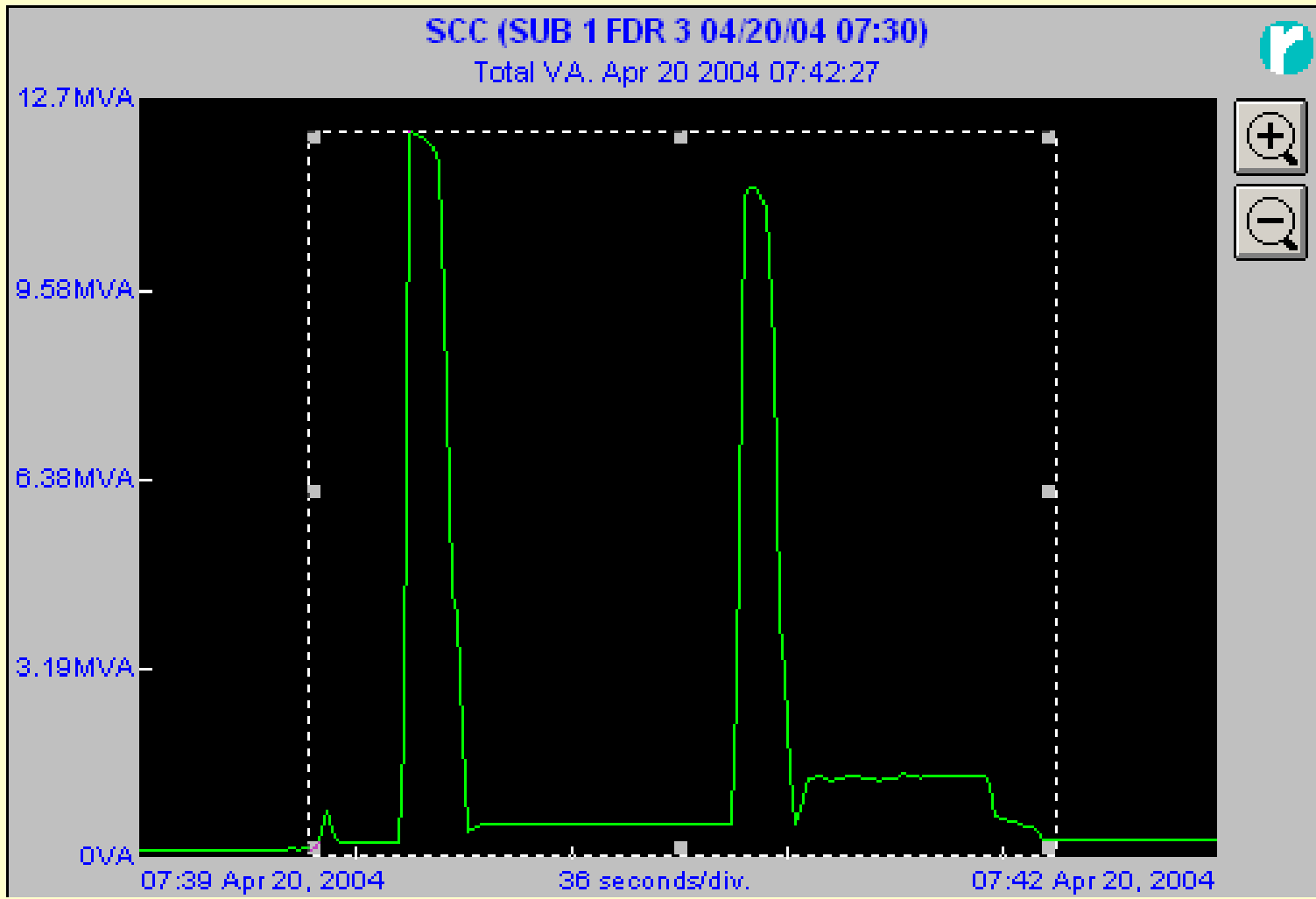

From:
4/20/2004
7:39:51

To:
4/20/2004
7:41:59

Span:
2:08

Peak:
12.2 MVA

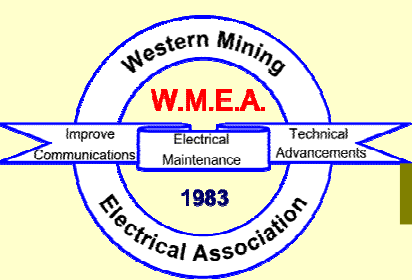

Soft-Start Power System Data Peak MVA Synchronizing MG 1

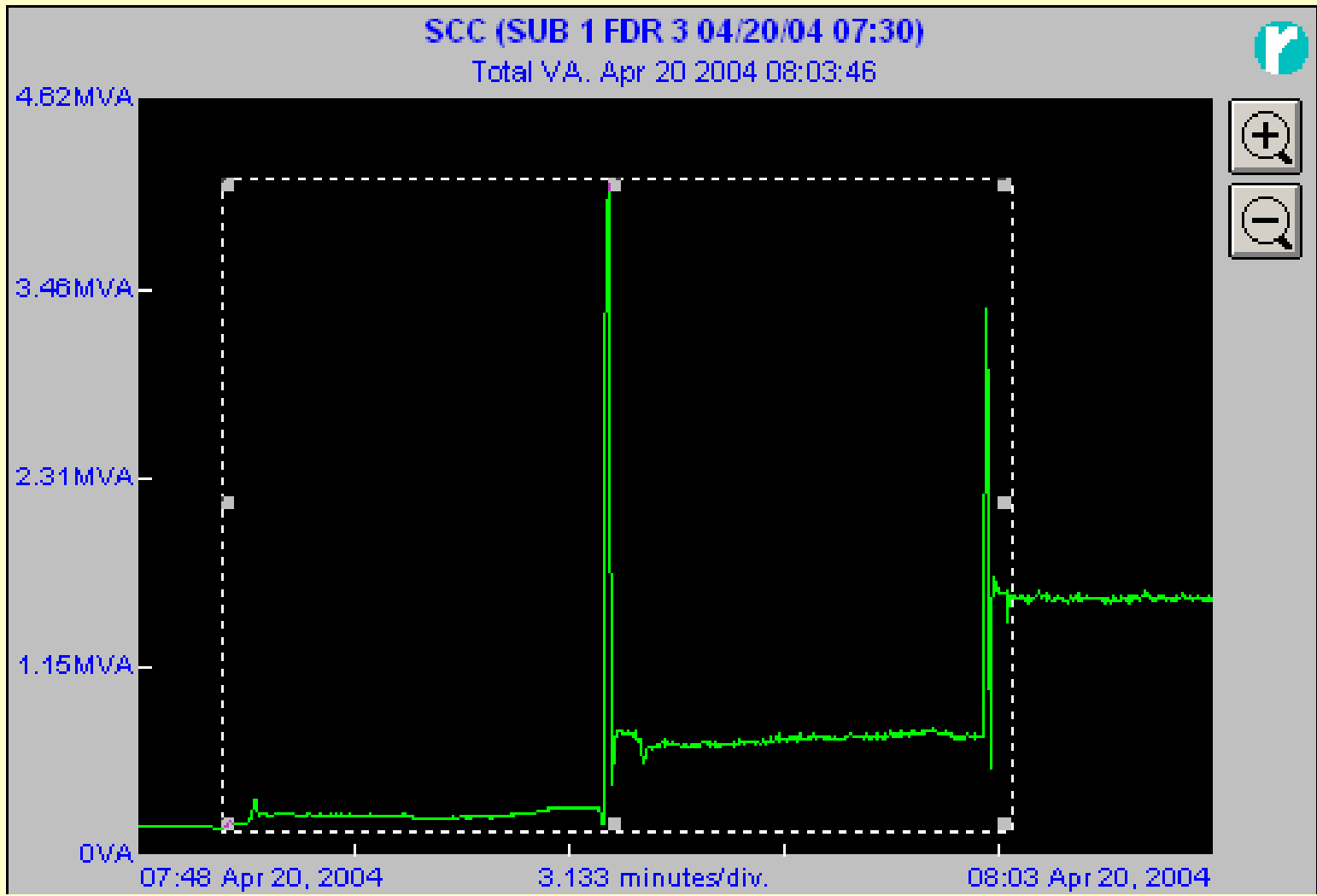

From:
4/20/2004
7:49:16

To:
4/20/2004
8:00:50

Span:
11:34

Peak:
4.0 MVA

Acceleration:
< 1 MVA

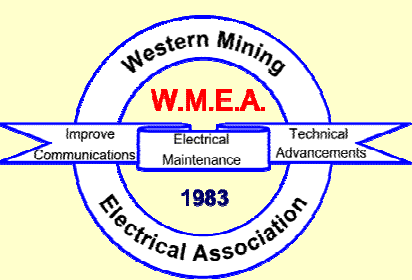

ATL Power System Data

Voltage Drop Starting MG 1

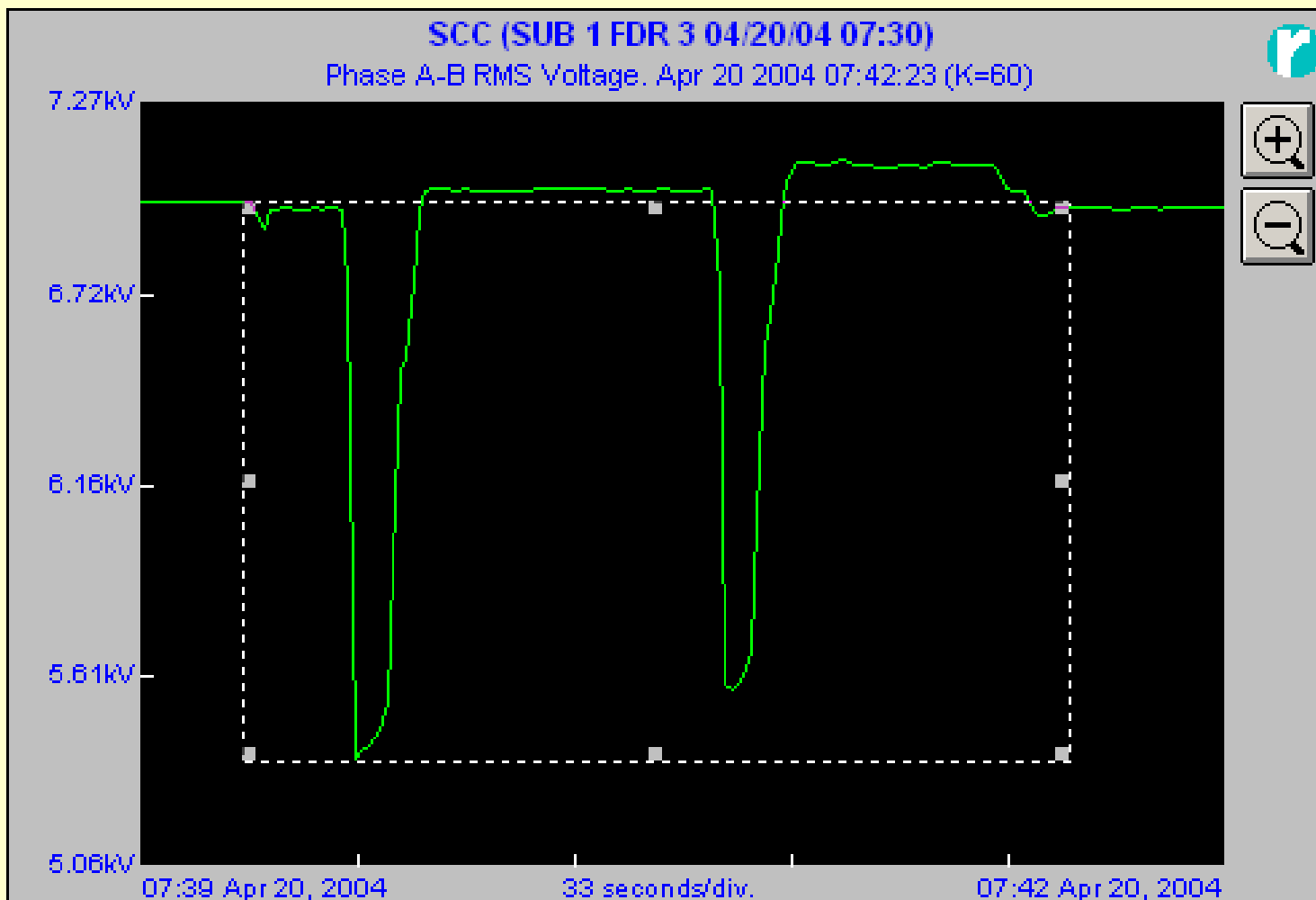

From:
4/20/2004
7:39:51

To:
4/20/2004
7:41:59

Span:
2:08

V Max:
6.99 Kv

V Min:
5.36 Kv

P-P:
1.63 Kv

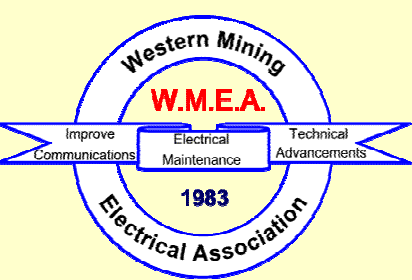

Soft-Start Power System Data

Voltage Drop Starting MG 1

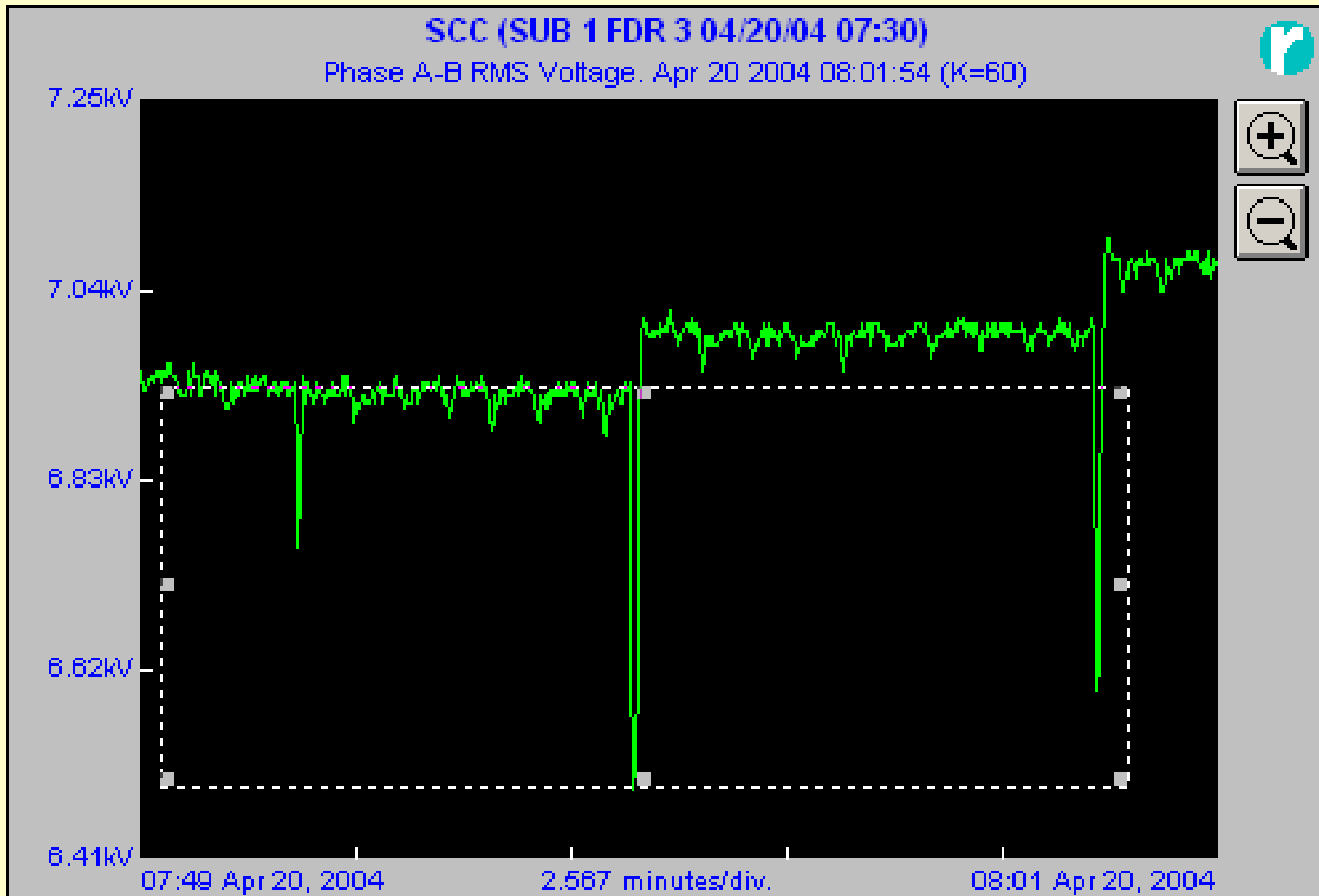

From:
4/20/2004
7:49:16

To:
4/20/2004
8:00:50

Span:
11:34

V Max:
6.94 Kv

V Min:
6.49 Kv

P-P:
< .5 Kv

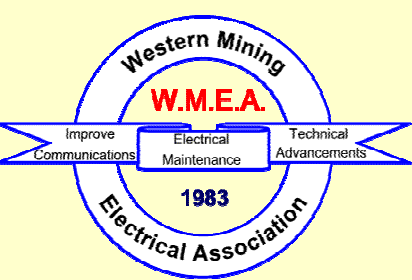

ATL Power System Data Inrush Current Starting MG 1

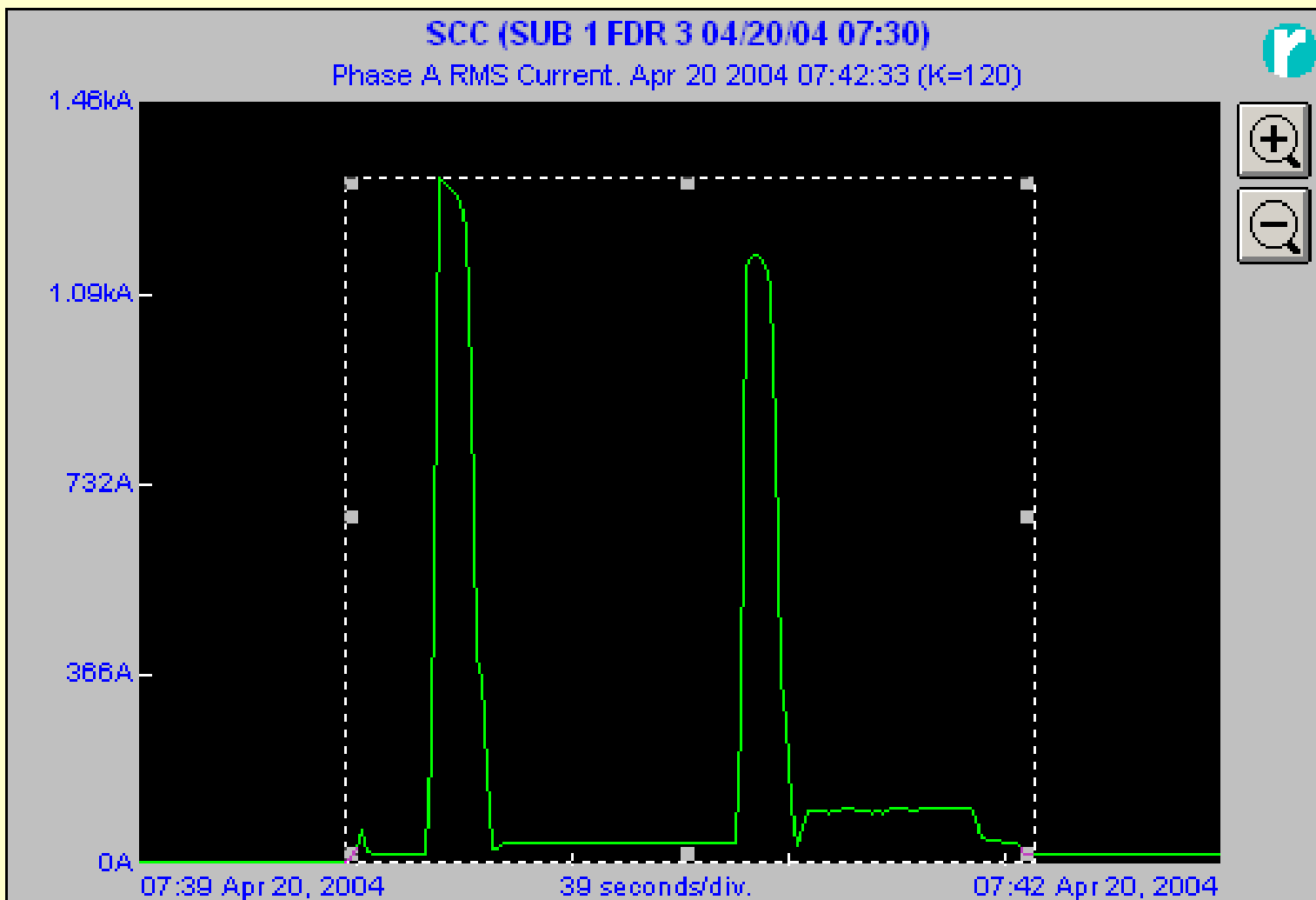

From:
4/20/2004
7:39:51

To:
4/20/2004
7:41:59

Span:
2:08

I inrush:
1321 Amp

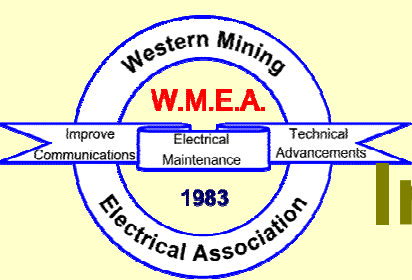

Soft-Start Power System Data Inrush and Acceleration Current

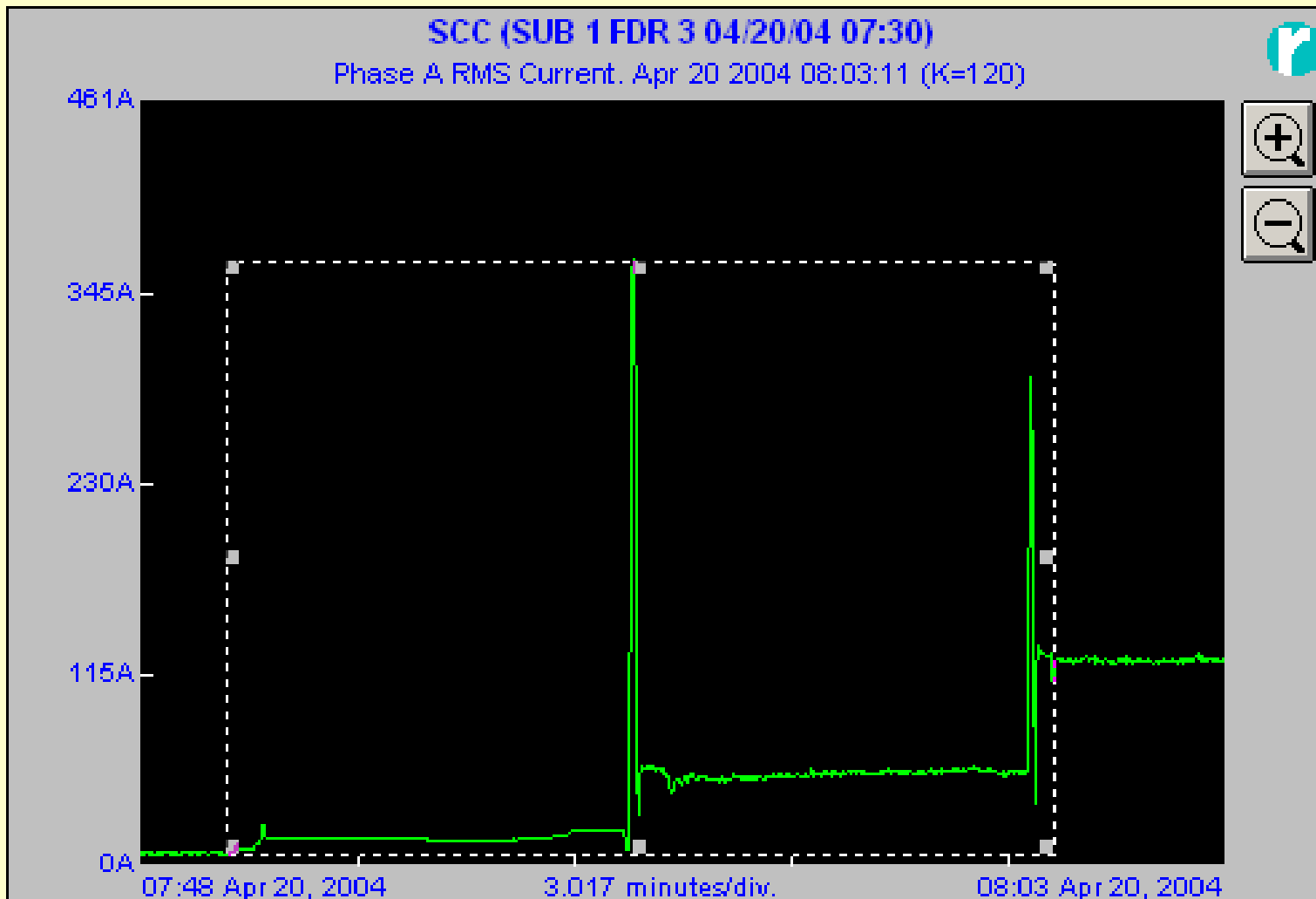

From:
4/20/2004
7:49:16

To:
4/20/2004
8:00:50

Span:
11:34

I inrush:
359 Amps

Acceleration:
< 100 Amps

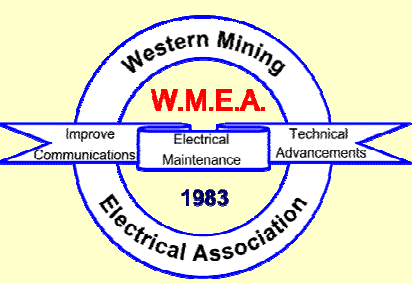

Demand Costs Higher or Lower?



Two components to electrical supply costs, demand and energy

Demand penalty for starting ATL is negligible compared to operating demands

Demand integrated over 30 minutes

- **We can operate on smaller cable because the current at peak operation is significantly less than inrush current at ATL start up**

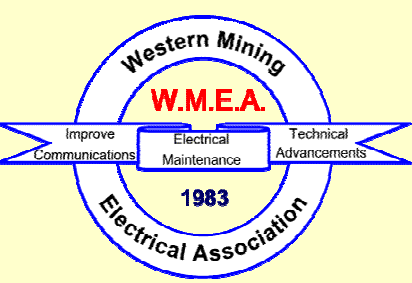

Quiz

What takes more energy?



- **Across the Line or Soft-Starting?**

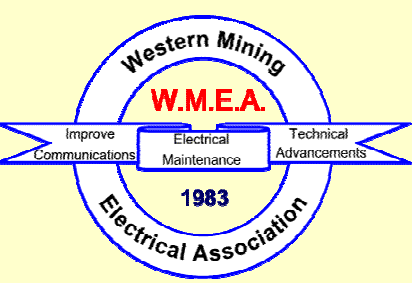

Quiz



- **Energy required to Soft-Start**
 »29.2 kWh
- **Energy required to start ATL**
 »29.6 kWh
- **Energy is the SAME**

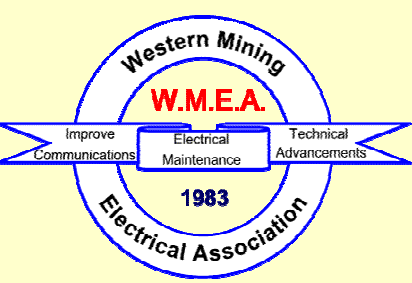

Conclusion



**Thank you for Opportunity
to Present this Topic**

**Questions or Comments?
See Jon Vendela!**

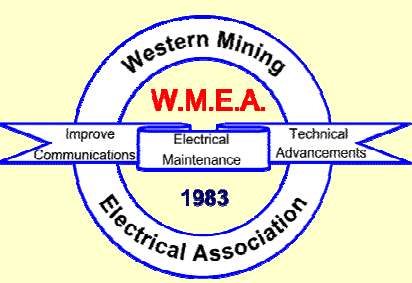

Power Illustrations



- The following power readings were recorded using a Reliable Power Meter Model 1656.
- The comparative charts of “across the line” starting and “soft” starting clearly illustrate the differences between Peak Mega Watts, Peak MVA, Voltage Drop, and Inrush Current.
- The benefits are apparent

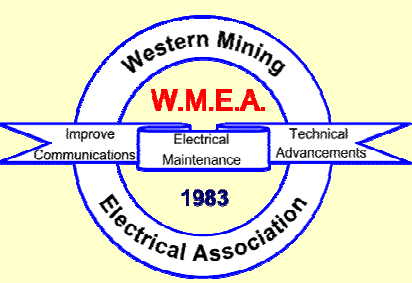

Material Needed



- **1200 Amp Armature Contactors (Siemens)**
- **200 Amp Field Reversing Contactors (Siemens)**
- **Phase Balance Relays (Basler)**
- **Frequency Transducers (Ohio Semitronics)**
- **7200 Volt PT's (Toshiba)**
- **Various small relays (Allen Bradley)**
- **PLC (Allen Bradley SLC 5/04)**
- **Extended armature and field wiring**